

6

5

4

3

2

1

D

D

C

C

B

B

A

A

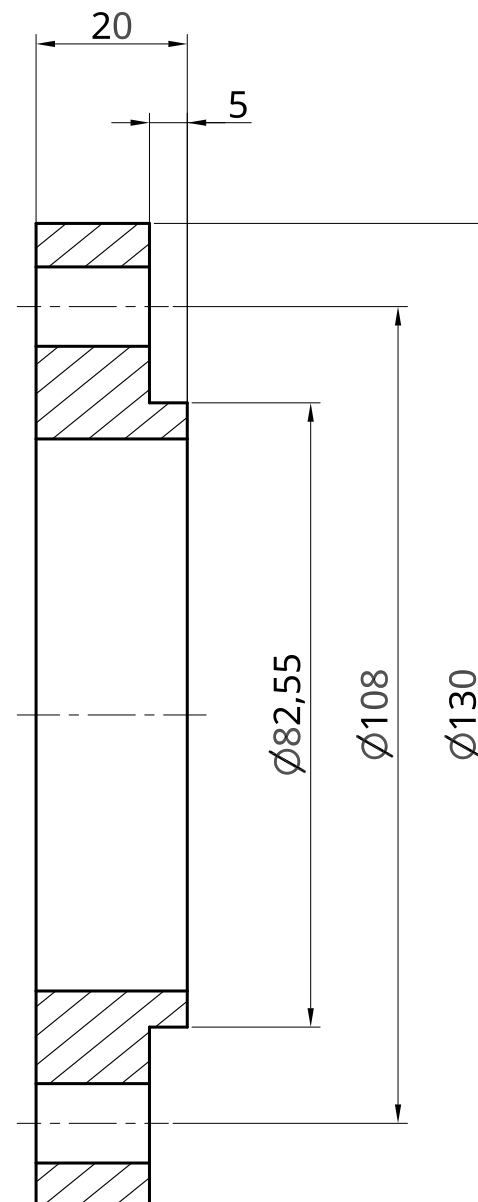
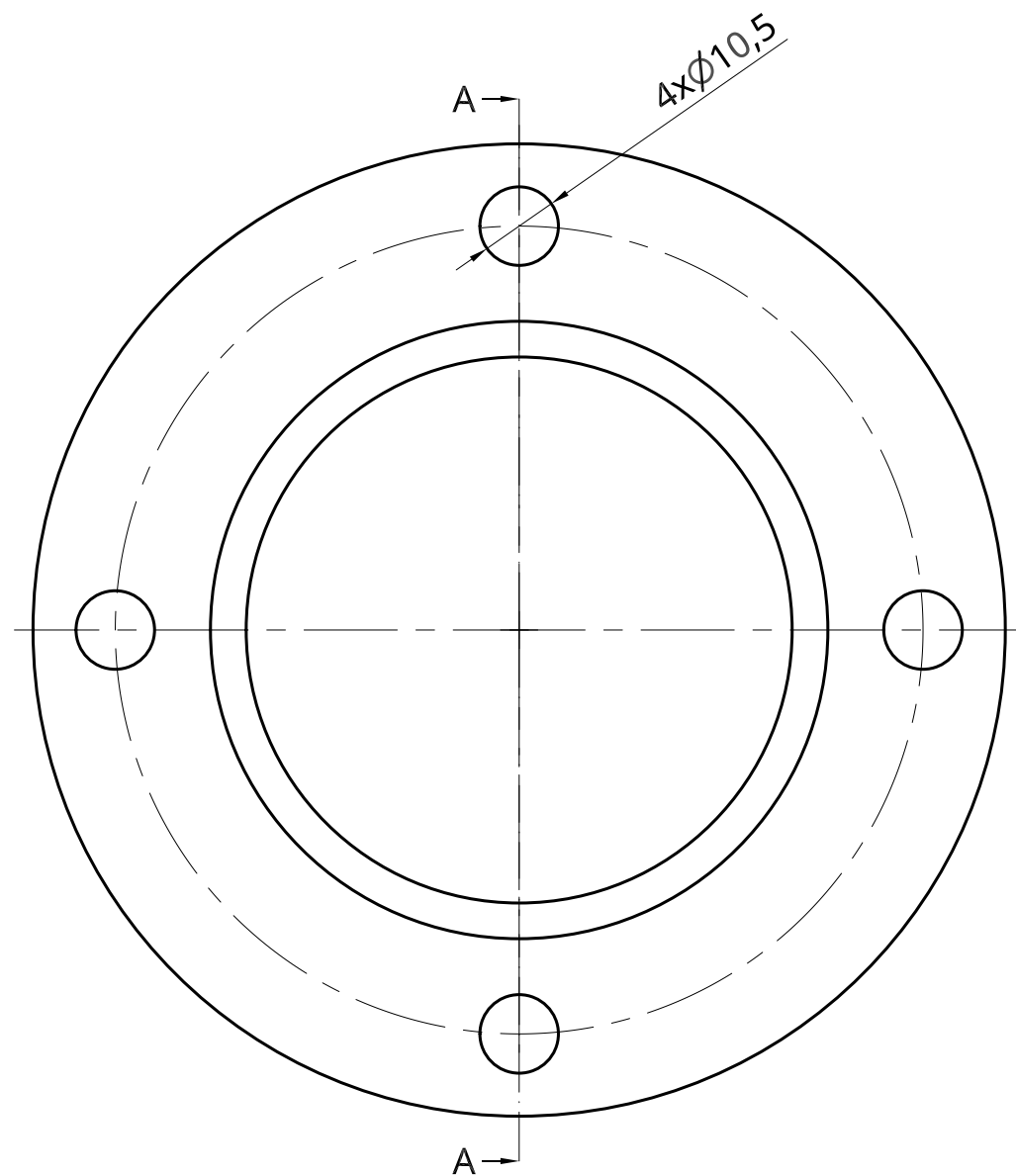

A - A

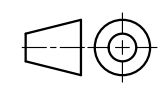

1:1

6

5

4

3

1